

PORTABLE GANTRY CRANE SPECIFICATIONS

Our Fixed Height Gantry Cranes are ideal for use in aircraft, automotive, and marine repair shops. They also work well in warehouses, machine shops, and loading areas. Gantry cranes are supplied with four roller-bearing steel wheels for easy maneuverability. The structural steel legs are welded together at the factory. Gantry crane requires assembly before use.

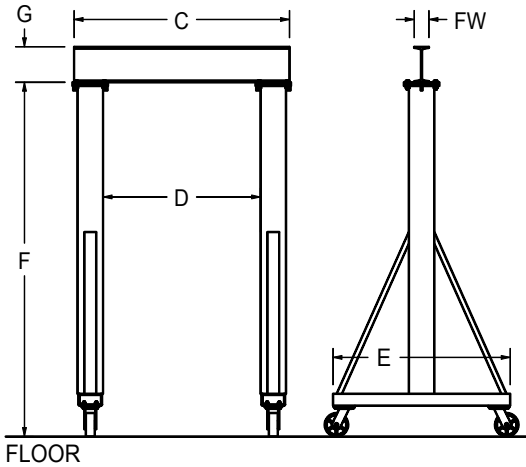

FIXED HEIGHT GANTRY CRANE SPECIFICATIONS										
MODEL NUMBER	CAP. (TONS)	STEEL * WHEELS	C	D	E	F	G	FW	BEAM TYPE**	WEIGHT (LBS.)
GC1-8	1	5" X 1 5/8"	9'-5"	8'	5'	10'	5"	3"	S	522
GC1-12	1	5" X 1 5/8"	13'-5"	12'	5'	10'	6"	3 3/8"	S	590
GC1-16	1	5" X 1 5/8"	17'-5"	16'	5'	10'	8"	4"	S	749
GC2-8	2	8" X 1 1/2"	9'-6"	8'	5'	10'	6"	3 3/8"	S	740
GC2-12	2	8" X 1 1/2"	13'-6"	12'	5'	10'	8"	4"	S	910
GC2-16	2	8" X 1 1/2"	17'-6"	16'	5'	10'	10"	4 5/8"	S	1062
GC3-8	3	8" X 2 1/2"	9'-6 5/8"	8'	5'	10'	8"	4"	S	1020
GC3-12	3	8" X 2 1/2"	13'-6 5/8"	12'	5'	10'	10"	4 5/8"	S	1188
GC3-16	3	8" X 2 1/2"	17'-6 5/8"	16'	5'	10'	13-5/8"	8"	W	1603
GC4-8	4	8" X 3"	9'-8 5/8"	8'	5'	10'	10"	4-5/8"	S	1292
GC4-12	4	8" X 3"	13'-8 5/8"	12'	5'	10'	10"	4 5/8"	S	1576
GC4-16	4	8" X 3"	17'-8 5/8"	16'	5'	10'	13-5/8"	8"	W	2001
GC5-8	5	8" X 3"	9'-8 5/8"	8'	5'	10'	16-3/8"	7-1/8"	W	1728
GC5-12	5	8" X 3"	13'-8 5/8"	12'	5'	10'	16-3/8"	7-1/8"	W	2050
GC5-16	5	8" X 3"	17'-8 5/8"	16'	5'	10'	16-3/8"	7-1/8"	W	2383

* DIAMETER OF WHEELS BY TREAD WIDTH

** "S" type beams are standard beams with tapered flanges. "W" type beams are wide-flange beams with flat flanges. The trolley used on a "W" type beam must be designed to operate on a wide-flange beam.

Our Telescopic Height Gantry Cranes have the same abilities as our fixed height gantries with the added benefit of raising or lowering the beam to suit your need. The beam will adjust from 8'-0" to 12'-0" below the beam with positive stops every 6". The beam is raised and lowered with the aid of two cable pullers (included). Locking pins hold the beam at the desired height.

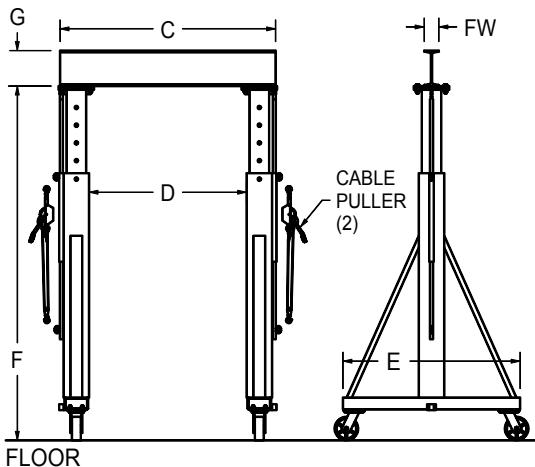

TELESCOPING HEIGHT GANTRY CRANE SPECIFICATIONS											
MODEL NUMBER	CAP. (TONS)	STEEL * WHEELS	C	D	E	F		G	FW	BEAM TYPE**	WEIGHT (LBS.)
						MIN.	MAX.				
GCT1-8	1	5" X 1 5/8"	9'-5 9/16"	8'	5'	8'	8'	5"	3"	S	827
GCT1-12	1	5" X 1 5/8"	13'-5 9/16"	12'	5'	8'	12'	6"	3 3/8"	S	895
GCT1-16	1	5" X 1 5/8"	17'-5 9/16"	16'	5'	8'	12'	8"	4"	S	1054
GCT2-8	2	8" X 1 1/2"	9'-6 5/8"	8'	5'	8'	12'	6"	3 3/8"	S	977
GCT2-12	2	8" X 1 1/2"	13'-6 5/8"	12'	5'	8'	12'	8"	4"	S	1167
GCT2-16	2	8" X 1 1/2"	17'-6 5/8"	16'	5'	8'	12'	10"	4 5/8"	S	1319
GCT3-8	3	8" X 2 1/2"	9'-6 5/8"	8'	5'	8'	12'	8"	4"	S	1147
GCT3-12	3	8" X 2 1/2"	13'-6 5/8"	12'	5'	8'	12'	10"	4 5/8"	S	1315
GCT3-16	3	8" X 2 1/2"	17'-6 5/8"	16'	5'	8'	12'	13-5/8"	8"	W	1730
GCT4-8	4	8" X 3"	9'-8 5/8"	8'	5'	8'	12'	10"	4-5/8"	S	1477
GCT4-12	4	8" X 3"	13'-8 5/8"	12'	5'	8'	12'	10"	4 5/8"	S	1761
GCT4-16	4	8" X 3"	17'-8 5/8"	16'	5'	8'	12'	13-5/8"	8"	W	2186
GCT5-8	5	8" X 3"	9'-8 5/8"	8'	5'	8'	12'	16-3/8"	7-1/8"	W	1905
GCT5-12	5	8" X 3"	13'-8 5/8"	12'	5'	8'	12'	16-3/8"	7-1/8"	W	2227
GCT5-16	5	8" X 3"	17'-8 5/8"	16'	5'	8'	12'	16-3/8"	7-1/8"	W	2560

* DIAMETER OF WHEELS BY TREAD WIDTH

** "S" type beams are standard beams with tapered flanges. "W" type beams are wide-flange beams with flat flanges. The trolley used on a "W" type beam must be designed to operate on a wide-flange beam.

FIXED & TELESCOPING GANTRY CRANES

Semi-steel heavy-duty swivel casters with roller bearings are standard equipment. Two casters are supplied with brakes.

Gantries are easily disassembled and assembled for relocation.

Contact factory for special heights, spans, and options.



1377 Kimberly Drive
Neenah, WI 54956-1642
Phone (920) 722-0101
Fax (920) 725-1394

www.contrx.com