

# PIVOT BOOM JIB LIFT

CENTER OF GRAVITY LOCATION

SINGLE HOOK CAPACITIES				
Hook Pos.	Hook Position (inches)	4000 LB. CAP.	6000 LB. CAP.	8000 LB. CAP.
A	34	4000	6000	8000
B	44	4000	6000	8000
C	54	4000	6000	8000
D	64	4000	6000	8000
E	74	4000	6000	8000
1	80	4000	6000	8000
2	87-1/2	3535	5302	6974
3	95	3167	4750	6182
4	102-1/2	2868	4302	5551
5	110	2621	3931	5037
6	117-1/2	2413	3619	4610
7	125	2235	3353	4250
8	132-1/2	2082	3123	3942
9	140	1949	2923	3676

CAP. (LBS)	MODEL NUMBER	DIM. "S"	DIM. "W"	DIM. "TL"	DIM. "H.U.B."	DIM. "OAH"	FORK POCKETS	WT. (LBS)
4000	PB-JLT424	24"	30"	24"	18-1/2"	30-1/2"	2-1/2" X 5-1/2"	491
4000	PB-JLT436	36"	44"	24"	19-1/2"	31-1/2"	3-1/2" X 7-1/2"	588
6000	PB-JLT624	24"	32"	24"	19-1/2"	32"	3-1/2" X 7-1/2"	640
6000	PB-JLT636	36"	44"	24"	23-1/2"	36"	3-1/2" X 7-1/2"	718
8000	PB-JLT836	36"	44"	32"	27-1/2"	41-3/4"	3-1/2" X 7-1/2"	966
8000	PB-JLT848	48"	56"	32"	27-1/2"	41-3/4"	3-1/2" X 7-1/2"	1025

DIM. "XX"	DIM. "X"	DIM. "Y"
39.7"	26.7"	16.5"
36.5"	25.2"	16.7"
41.2"	27.0"	16.2"
38.2"	25.5"	17.2"
38.0"	26.0"	19.7"
35.0"	24.6"	17.4"

**IMPORTANT**  
TRUCK FORKS MUST EXTEND THROUGH FULL LENGTH OF FORK TUBES

THIS CHART LISTS SAFE WORKING LOADS FOR THE JIB LIFT ONLY. IT DOES NOT CONSIDER THE FORK TRUCK BEING USED. CONSULT THE FORK TRUCK MANUFACTURER FOR SAFE LOAD CAPABILITIES WITH THIS ATTACHMENT BEFORE USING.

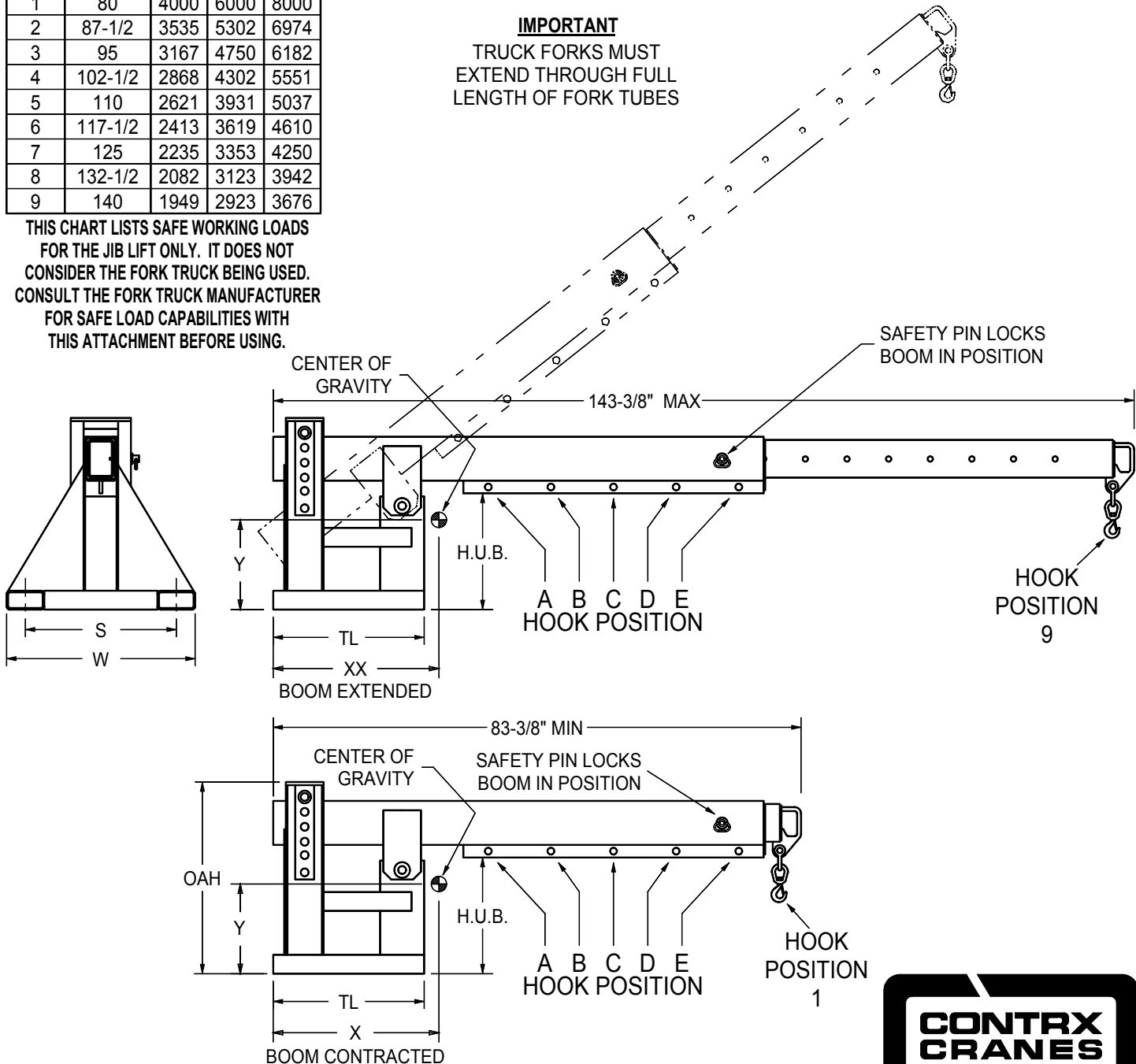

**FEATURES**

- Handles long loads in closed trucks
- High and long reaches for inaccessible areas
- High underclearances and bulky load handling
- Adjustable at 10° increments from horizontal to 50°
- Safety chain secures jib lift to forklift truck



1377 Kimberly Drive  
Neenah, WI 54956-1642  
Phone (920) 722-0101  
Fax (920) 725-1394  
[www.contrx.com](http://www.contrx.com)